

The answer to 24/7 PRV monitoring.

In the petrochemical and refining industry, pressure relief and isolation valves present a challenge in event tracking and minimizing base load to flare systems. Continuous monitoring is the only way to pinpoint the source of pressure release events and leaks as soon as they occur, so maintenance can be performed right away.

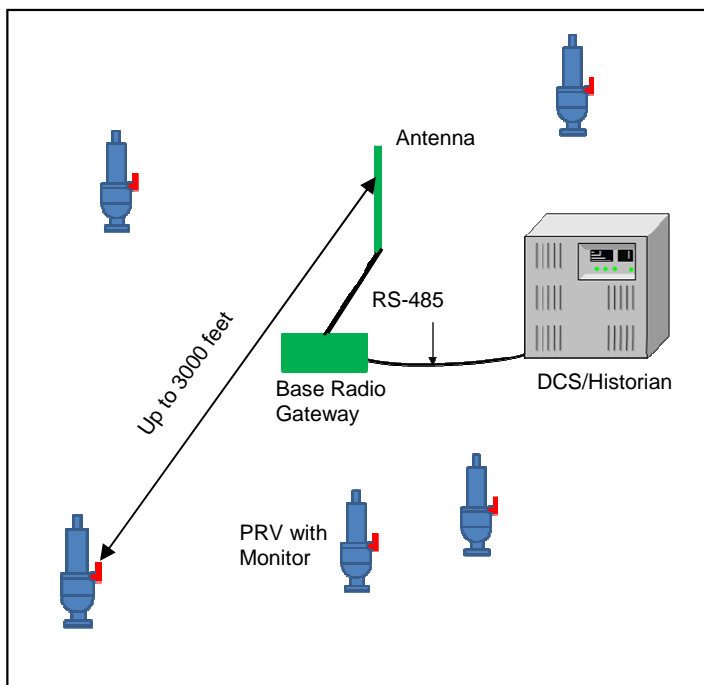

System Diagram



AWS—it's the proven advantage.

The only true wire-free, complete system on the market today, the AWS solution is an easy-to-implement, turnkey approach to monitoring that interfaces with your current systems. It allows you to watch process conditions 24/7.

Absolutely no field wires! No permits. No licenses. AWS frequencies and protocol coexist with no negative impact on other wireless systems.

This is a ready-to-go, robust system solution that includes everything you need—intrinsically safe battery-operated field units with sensors and transceivers; base radio transceiver gateways, capable of communicating with up to 100 field units per second; user-selectable output options readily interfaced with existing systems. AWS software provides tools for remote configuration and network management. The units are individually calibrated between -40° and $+185^{\circ}\text{F}$. All instruments are certified by the FCC, for license-free use in the ISM band. System elements are not IP addressable for automation security.

System Characteristics

- **Cost effective:** Enables extension of inspection and test cycles.
- **Convenient:** Monitors devices that are difficult to access.
- **Continuous monitoring:** 24/7 monitoring identifies events and leaks as soon as they happen.
- **Easy to install:** Non-invasive system, no penetration required, can be re-located as needed.
- **Secure:** Protocol provides security against, denial of service attacks, unauthorized data reading and collection of false messages.
- **Versatile:** Measures duration of overpressure events; identifies source of material sent to flare.
- **Reliable:** Frequency Hopping Spread Spectrum (FHSS) technology.
- **Robust:** All components can withstand harsh industrial environments, and are rated Intrinsically safe for use in all hazardous areas.
- **Long-range:** Wireless transmission up to 3,000 feet

Valve Monitor Field Units



Valve monitor field units consist of sensors, signal conditioning and communication elements that are packaged with antenna and mounting accessories appropriate for all types of valves and locations.

RF transceivers use 902 MHz – 928 MHz FHSS ISM band, FCC certified for license free use.

Frequency and protocol delivers superior communication range and battery life:
Distance – 3000 feet clear line of sight; 500 to 1000 feet obstructed; optional high gain antennas and remote sensor/antenna configurations
Battery – 3.6V lithium size C, 5 years in normal monitoring configuration, field changeable. Optional D size doubles battery life.

Performs self-diagnostics, alerting user of potential hardware failures and low battery status

NEMA 4X weather-proof

Intrinsic Safety: Intrinsically Safe for Class I, Div 1, Groups A,B, C & D & Class II Div 1, Groups E, F, & G & Class III Div 1. EEx Intrinsically Safe Zone 0.



Base Radio Gateways

902 MHz – 928 MHz FHSS ISM band
Transceiver communicates with up to 100 field units. Output options – RS485, dual channel, Modbus slave and various protocol converters; RS-232, TCP, and optional 4-20 mA signals.

Performs data collection from field units, enables remote configuration of field units and interface to existing systems.

Automatic diagnostic and monitoring of the RF signal with all valve monitors. Multiple base radios can be used to provide redundancy and increase the total number of field units.

Network Software

Diagnostic and performance monitoring of individual sensors, radios, batteries and valve status. Remote management of the entire wireless sensor network.

Access Control to provide users with various levels of read/write authority. Configuration management password protected for tamper proof control.

Data logging with export feature to integrate with existing data bases and reporting systems suitable for temporary data acquisition applications.

