

Quick Start Guide

The AWS Base Radio Repeater comes preconfigured and is ready to use out of the box. This section is divided based on two protocols: WIM and Modbus. Follow the diagrams and instructions below to set up the Base Radio Repeater using the defaults. Numbers in the figure correspond to instruction steps.

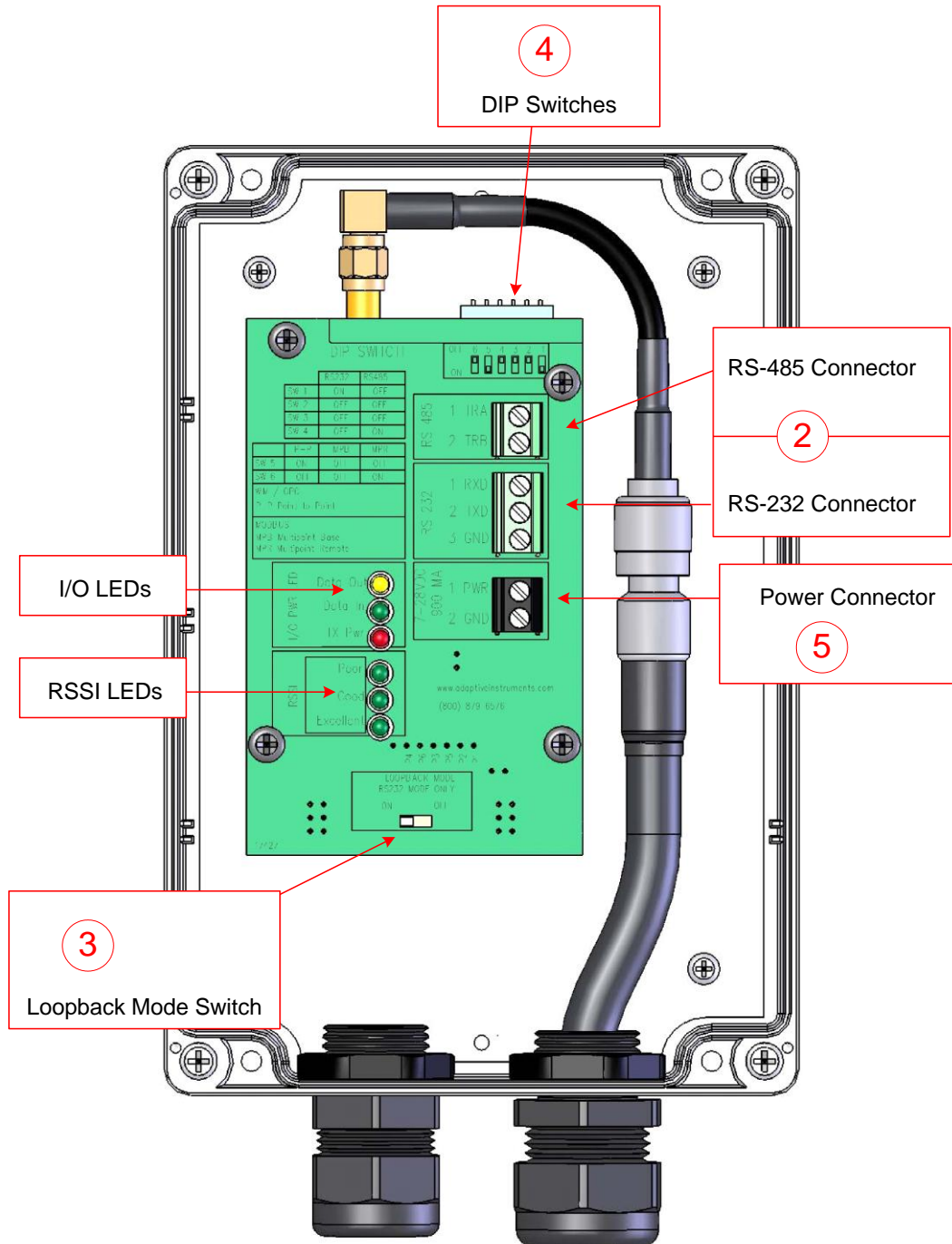

WIM

Refer to the diagram on page 1.

Step 1: WIM Remote Base Radio Repeater

1. Remove the cover by unscrewing the 4 corner screws.
2. Feed the RS-485 wires through the hole in the bottom of the case, then connect Base Radio output A to BRR input TRB, and Base Radio output B to BRR input TRA.

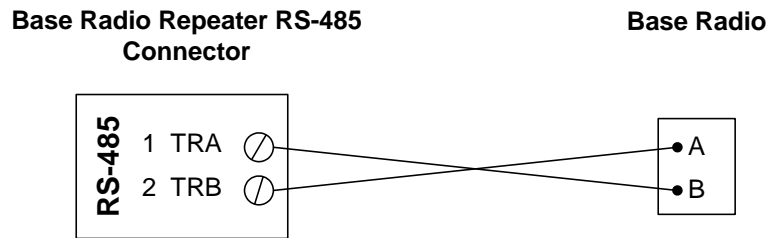

3. Make sure the Loopback switch is in the OFF (Right) position.
4. Make sure the DIP switches are set to the following positions:

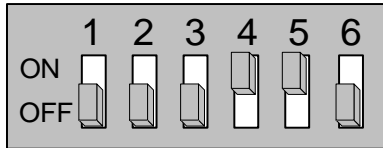

5. Connect power to the power terminals of the BRR through the hole in the bottom of the case.

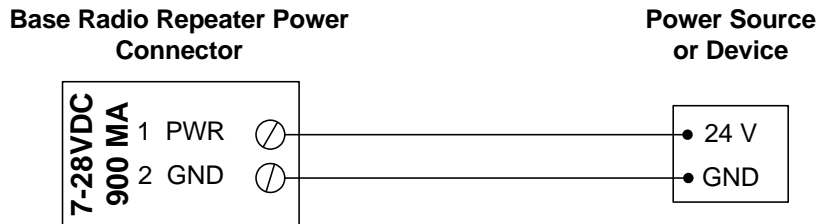

6. Reattach the cover.

Results

The **Green Data In** I/O LED should flash roughly once a second as the base radio's data is transmitted through the Base Radio Repeater.

Step 2: WIM Based Base Radio Repeater

1. Remove the cover by unscrewing the 4 corner screws.
2. Feed the RS-232 wires through the hole in the bottom of the case, then connect the serial cable to the 3 RS-232 connectors on the BRR.

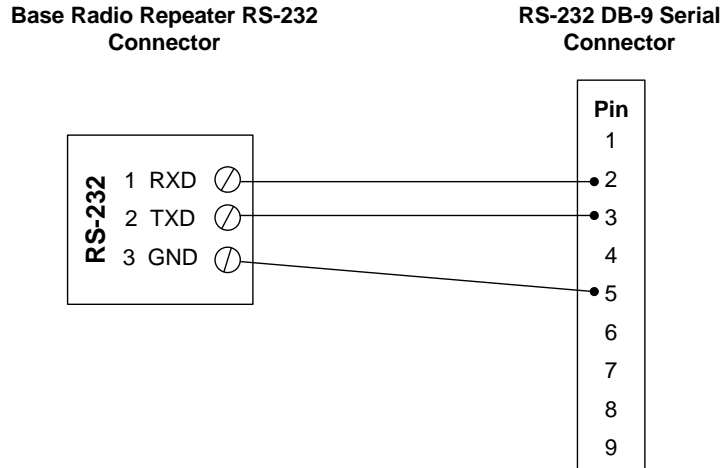

3. Make sure the Loopback switch is in the OFF (Right) position.
4. Make sure the DIP switches are set to the following positions:

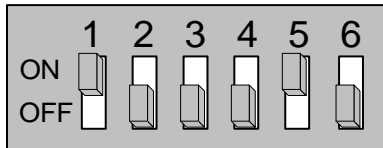

5. Connect power to the power terminals of the BRR.

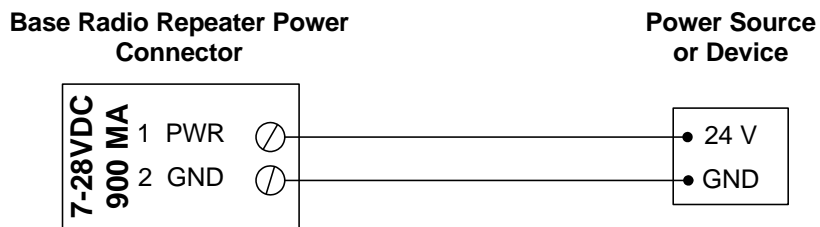

6. Connect RS-232 into the computer running WIM.
7. Reattach the cover.

Results

If the Remote Base Radio Repeater has been set up, the **Yellow Data Out** I/O LED should flash roughly once a second as the Remote Base Radio Repeater's data is received and relayed to the computer.

Modbus

Refer to the diagram on page 1.

Step 1: Modbus Remote Base Radio Repeater

1. Remove the cover by unscrewing the 4 corner screws.
2. Feed the RS-485 wires through the hole in the bottom of the case, then connect Base Radio Modbus output A to BRR input TRB, and Base Radio Modbus output B to BRR input TRA.

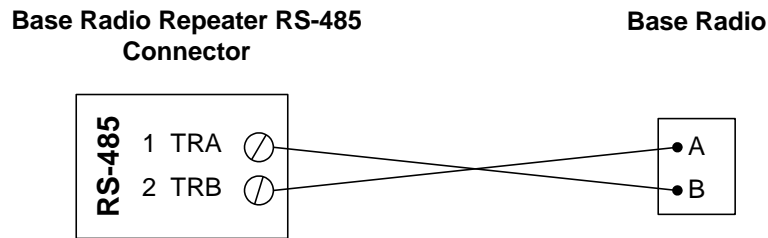

3. Make sure the Loopback switch is in the OFF (Right) position.
4. Make sure the DIP switches are set to the following positions:

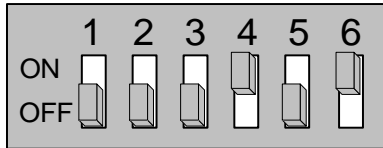

5. Connect power to the power terminals of the BRR.

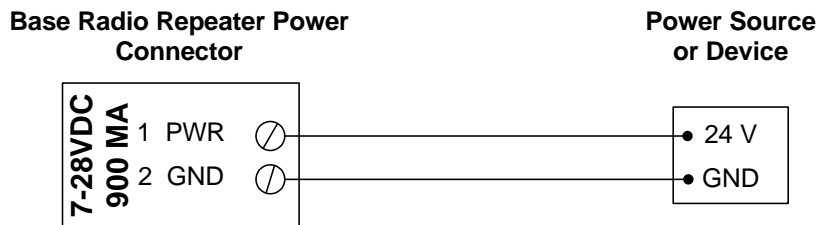

6. Reattach the cover.

Results

When the Base Base Radio Repeater is set up and the Modbus master is polling, the **Yellow Data Out** I/O LED should flash every time a poll is received, and the **Green Data In** I/O LED should flash when the Base Radio Modbus slave responds to the poll.

Step 2: Modbus Base Radio Repeater

1. Remove the cover by unscrewing the 4 corner screws.
2. Feed the RS-232 wires through the hole in the bottom of the case, then connect the serial cable to the 3 RS-232 connectors on the BRR.

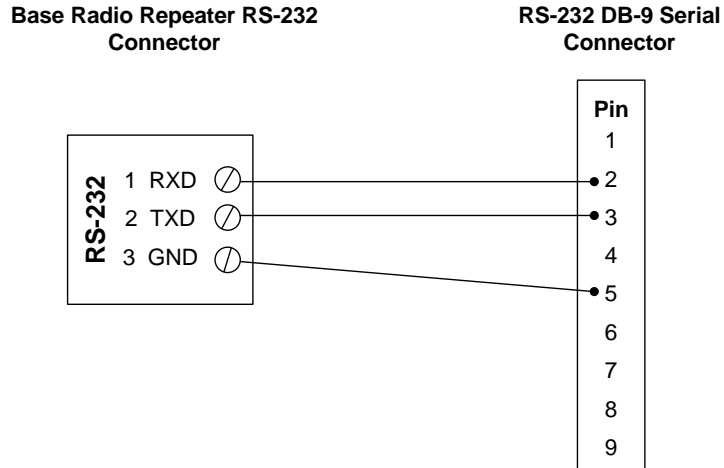

3. Make sure the Loopback switch is in the OFF (Right) position.
4. Make sure the DIP switches are set to the following positions:

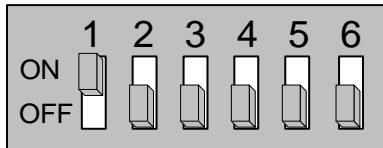

5. Connect power to the power terminals of the BRR.

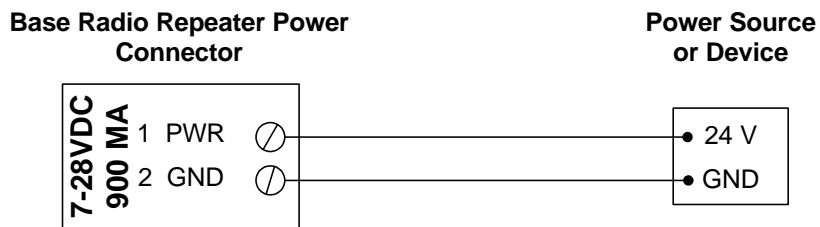

6. Connect the RS-232 cable to the computer running Modbus master software.
7. Reattach the cover.

Results

The **Green Data In** I/O LED should flash every time the Modbus software polls for data. Every time a response is received, the **Yellow Data Out** I/O LED should flash.