

Accutech™

Smart Process Instrumentation

MODEL
SC-2000

Two-Wire "Smart" Signal Conditioner

For High Precision Industrial
Measurements



Highlights

- **Exceptional Accuracy**
To $\pm 0.04\%$ of reading
- **Stability**
Exceptional repeatability: to $\pm 0.02\%$ of reading
Automatic self-calibration
Digital temperature compensation
Two-year calibration guarantee
- **Versatility**
Volt, millivolt, current, or resistance input
Normal or reverse acting output
No minimum span
- **Remote Communication**
2-wire, RS-232 compatible
Communication up to 5,000 feet
- **Ease of Use**
Conventional calibration, standard
Display setup, optional
PC configuration, optional
Hand-held terminal, optional
- **Field Proven Design**
Rugged, sealed, industrial design
Hardened to EMI/RFI interference
Suitable for field or panel mounting

Description

With the introduction of the SC-2000, Accutech extends "Smart" technology to signal conditioners. All of the power that digital processing has brought to "Smart" transmitters is now available for signal conditioning applications. The SC-2000 accepts a large variety of electrical inputs—volts, millivolts, milliamps, potentiometers, and resistance. Full isolation is provided along with virtually unlimited linearization capability.

The SC-2000 includes a host of standard features. Reverse action, up or down scale failsafe, elevated zero, unlimited rangeability, low input span, high input impedance for volt and millivolt inputs, and RFI/EMI protection are all standard on the SC-2000. Also included on the SC-2000 as "standard" features are the advanced capabilities of digital ambient temperature compensation, remote communications, automatic self-calibration, traceability to NIST, and even a 24-month calibration guarantee.

With all these "Options" included in every SC-2000, you will no longer need to stock large numbers of spare parts. As conditions change, you will not need to send your signal conditioners back to the factory to have new options installed or throw away units that are not correctly configured for the task at hand.

The Accutech SC-2000 is the only signal conditioner with "Smart Communication." This patented communication technique gives you the freedom to choose any one of four communication methods, while retaining the ease-of-use programming capabilities that are familiar to Accutech users.



Applications in Industrial Service

For field or panel mount applications—the SC-2000 will convert a current, voltage, or resistance input to a 4 to 20 mA output. It provides linearization, isolation, and gives you complete freedom to choose the output range that meets your needs. All of this capability is included in the SC-2000. It can be specified without options and is the ideal universal interface module.

As an Isolator

The SC-2000 provides up to 850 VDC input/output isolation. This allows a low level electrical signal to pass from one circuit with one ground level to a second circuit with a second ground potential. In many industrial applications, it is not uncommon for various ground levels to be separated by many volts from ground potentials in other parts of the plant. Isolating these ground potentials with the SC-2000 allows signals to pass without creating a direct current path between ground potentials.

As a Linearizer

The SC-2000 can linearize almost any input. Square, square-root, and logarithmic functions are easily selected. For more difficult linearization tasks, a 21-point custom linearization curve may be input in the field. Digital communication and the ability to display the selected curves simplify recordkeeping. The record is retained in the SC-2000 and is always available.

As a Noise Suppressor

In industrial applications, the effect of electrical noise on process control signals can be detrimental. Low level voltage and millivolt signals are particularly vulnerable. The SC-2000 filters out noise and converts the low level input signal to a higher level milliamp output signal, which is much less susceptible to the effects of electrical noise.

Where Maximum Performance is Necessary

In many process industry applications, precision measurements are necessary for maximum production throughput and highest product quality. The SC-2000 is right at home in these applications. Its accuracy, repeatability, and long-term stability are unmatched. Accutech 2000 series products have been proven in the most demanding applications. You can feel comfortable giving these instruments the most difficult signal conditioning tasks you have.

Where Standardization is Advantageous

The SC-2000 can handle the toughest operations in the plant. At the same time, it is cost-effective enough to be used in less demanding locations and versatile enough to be used wherever signal conditioning is called for. Standardizing on the SC-2000 affords across-the-board savings in personnel training and storeroom inventories.

Where Remote Communications Pays Dividends

Remote communications can pay big dividends. In start-up, if you need to change a range, you can do this right from the control room in just a couple of minutes. During operation, if you suspect a problem, you can just call up the SC-2000. There is no need to leave the control room to troubleshoot. Industrial studies have shown that savings that result from remote communications alone are worth \$350 per point **annually** !

Where Elimination of Periodic Maintenance Cuts Costs

The SC-2000 has built-in zero and full-scale calibration checks performed every three seconds. This automatic, self-calibration virtually eliminates the need for manual periodic recalibration. The SC-2000 also checks for internal failures and open inputs—significantly reducing your maintenance costs.

Where Guaranteed Accuracy Will Enhance Your Operations

The self-calibration features in the SC-2000 have been proven in industrial processes. They put a virtual end to periodic calibration maintenance. With years of real world experience behind it, Accutech now guarantees the SC-2000 to hold calibration to factory-specified tolerances for a period of two years! This guarantee gives you added assurance that your signal conditioner is giving you the precision information that you need to run your process at top efficiency.

Operation

Installation and operation are simple. Choose one of four configuration methods to set-up the signal conditioner. Select the desired input and output ranges. The independent zero and full-scale may be set anywhere without regard to minimum span or reverse action.

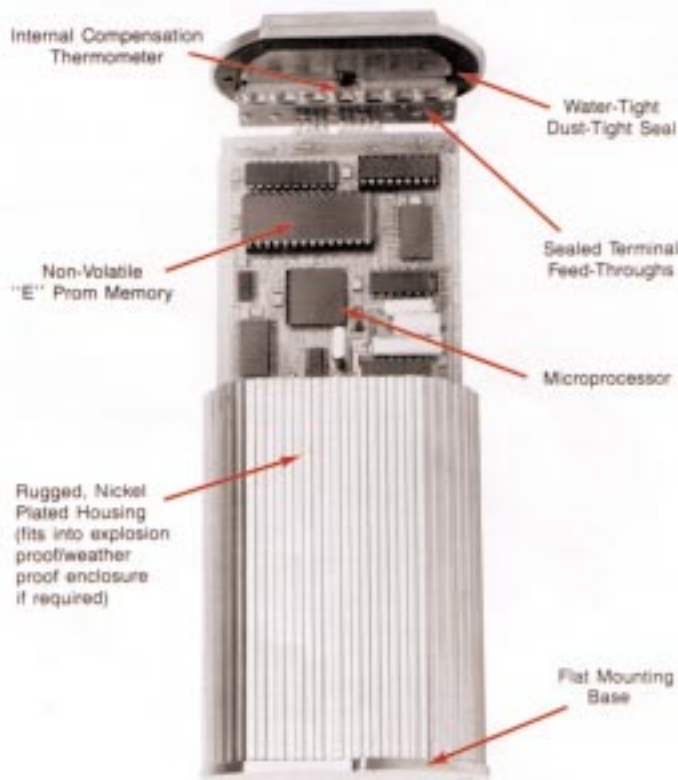

Industrial Construction

The SC-2000 is packaged in a rugged, nickel-plated, aluminum enclosure suitable for mounting on a flat surface. The sealed metal housing provides protection against moisture, condensation, and the effects of electromagnetic and radio frequency interference (EMI/RFI).

Inputs

The SC-2000 accepts the most popular electrical inputs. Selection is easily made in the field using conventional tools via the patented "Tap" mode, with the optional "Smart Display," with the CA-100 and a PC or with the HHT-420 hand-held terminal. Input and output can be grounded at different potentials. The SC-2000 will provide isolation to 850 V.

DC Volt Input

The SC-2000 will accept DC voltage inputs from -0.5 to $+5.0$ V. With voltage input, the input impedance is $1\text{ M}\Omega$.



Milliamp Input

Milliamp inputs from -5.0 to $+60$ mA can be accommodated. This allows both 4 to 20 mA, as well as 10 to 50 mA inputs. Input resistance $2.7\ \Omega$.

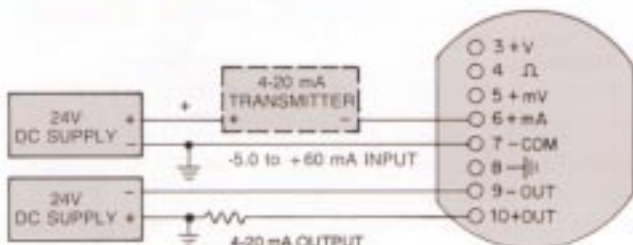

Potentiometer Input

For potentiometer, slidewire, and resistance input up to $1\text{ K}\Omega$ with low excitation current (0.33 mA pulsed) and very low self-heating of the input device.

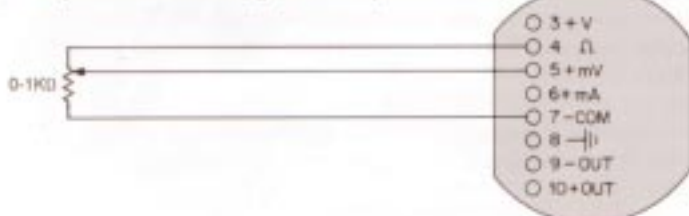

DC Millivolt Input

The millivolt input range extends from -15 to $+160$ mV. With millivolt input, impedance is greater than $10\text{ M}\Omega$.

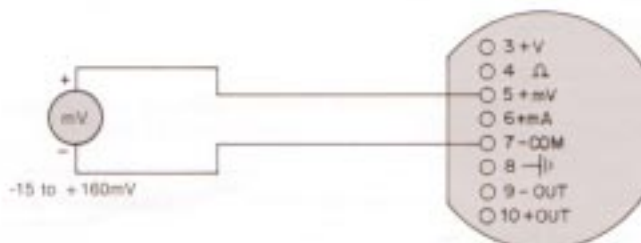

Product Features

Simple Installation

Installation requires only two low voltage wires which provide the 4 to 20 mA output signal and the power.

Automatic, On-Line Self-Calibration

In normal operation, the SC-2000 automatically checks zero and full-scale calibration reference standards every three seconds. Internal corrections are made, if necessary, without disturbing the 4 to 20 mA loop current.

Automatic Temperature Compensation

Critical circuit component temperatures are continuously measured and digitally compared to stored ambient temperature calibration data. This digital ambient temperature compensation maintains stable performance at any specified operating ambient temperature.

Factory Calibration

All Accutech 2000 series products undergo a rigorous factory calibration in ambient temperatures from -40 to $+167^\circ\text{F}$ (-40 to $+75^\circ\text{C}$). This factory calibration data is permanently retained in nonvolatile memory.

Through this automated procedure, the SC-2000 will give specified performance in real-world environments where the inputs, ambient temperature, and line voltage all vary at the same time—just the way you will use it.

NIST Traceability

Most international quality standards, such as ISO 9000, require traceable measurement instrumentation. These calibrations must consider the effects of temperature, rate of change of temperature, humidity, lightning, vibration, and dust. The factory calibration and physical construction of the Accutech 2000 series products take into account each of these factors. Included with each SC-2000 is a NIST traceable calibration certification.

Calibration Guarantee

International standards also require recalibration schedules to be established. Accutech 2000 series products cut your recalibration expense with a standard two-year calibration guarantee.

Dynamic Response

Signal conditioners are generally specified under laboratory conditions with stable inputs and stable ambient conditions. This is fine for the lab, but you need performance in the real world where conditions are changing rapidly. Accutech is the first manufacturer of signal conditioners to specify performance under dynamic conditions.

Remote Communication

The SC-2000 can function as a conventional two-wire signal conditioner or its advanced features can be accessed via digital communications along the same pair of wires. Connecting the CA-100 communications adapter module anywhere along the loop produces an RS-232 communications link for a process or personal computer. The Accutech HHT-420 can also be used for remote communication. These options are covered in more detail in the Accutech AI-2000 competitive comparison brochure.

Physical Dimensions

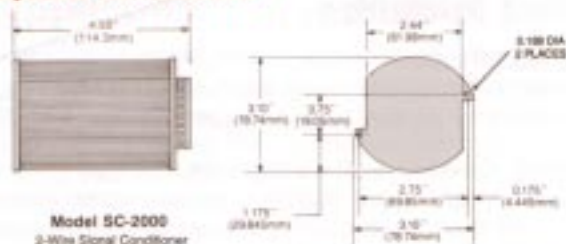

Model SC-2000
3-Wire Signal Conditioner

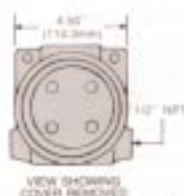

Model XP-HDC3-L
Optional Explosion-Proof Housing

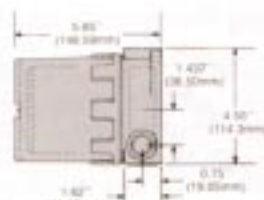

Connection Diagram

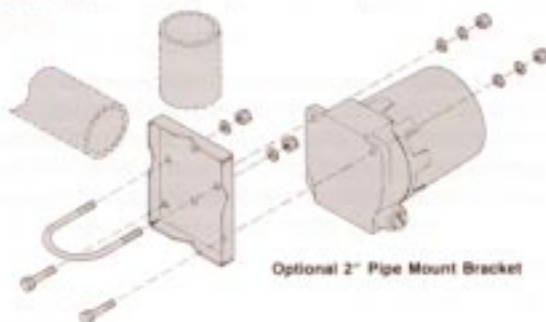

Optional 2" Pipe Mount Bracket

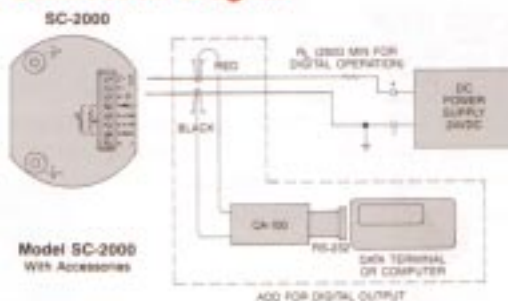

Model SC-2000
With Accessories

SC-2000 Specifications

Input Type	Range
DC Milliamp	-5.0 to +60.0 mA
DC Millivolt	-15.0 to +160 mV
DC Volt	-0.5 to +5.0 V ¹
Potentiometer, 3-Wire	0.0 to 1.0 KΩ ²
Resistance, 2- or 3-Wire	0.0 to 1.0 KΩ ²

¹10.0 VDC available, consult factory.
²10 KΩ available, consult factory.

Isolation: 850 VDC or peak AC

Linearization: Square, square-root, and log to ±0.05% of input. Custom linearization user programmable at 21 points.

Output: Two-wire, 4 to 20 mA

Digital, two-wire (RS-232, 300 baud with CA-100 adapter)

Output Ranging Adjustments

Zero:	} { 100% of Sensor Range—Noninteracting
Full-Scale:	
Digital Mode:	

Minimum Output Range: None

Output Resolution: Analog, 2.1 μA; Digital 0.001 mV

Accuracy: Includes repeatability, hysteresis, load, ambient temperature, effect and uncertainty of factory NIST traceable calibration equipment. Enhanced accuracy calibrations are available from the factory.

Digital Output Accuracy: ±0.04% of the millivolt or ohm equivalent reading, or the accuracy from the table below, whichever is greater.

Input	Accuracy
Milliamp	±0.005 mA
Millivolt	±0.008 mV
Volt	±0.003 V
Resistance	±0.12 Ω

Analog Accuracy: Digital accuracy plus ±4 μA.

Repeatability: One half of accuracy specification.

Reference Condition Accuracy: One-half of the accuracy specified above. When set up in the "Tap Mode," the SC-2000 is referenced to the prevailing

conditions. Accuracy at this reference condition includes repeatability, linearity, and hysteresis effects. ("Reference Condition Accuracy" is comparable in scope to the "Accuracy" or "Calibration Capability" generally specified for analog-based signal conditioners.)

Dynamic Response:

Turn on Time: Less than 5 seconds after power-up.

Changing Ambient Temperature: Automatic compensation to 20°C/hour change.

Update Time: Analog, 0.15 second; Digital, 1 second

Response to Step Input: Analog: 0.25 second, typical
Digital: 1 second, typical, to 95% of final value
5 seconds, to stated accuracy.

Ambient Operating Temperature: -40 to +167°F (-40 to +75°C)

Ambient Storage Temperature: -58 to +185°F (-50 to +85°C)

Ambient Temperature Stability: Self-correcting over the operating temperature range.

Long-Term Stability: Less than 0.05% of reading ±2.1 μA per year.

Automatic Diagnostics: Every 3 seconds, self-checks for zero, span, open resistance input, and malfunction.

Failsafe: Analog, user settable to 21 mA, 3.9 mA, or "OFF."
Digital, message, or "OFF."

Interchangeability: All units interchangeable without field calibration.

EMI/RFI Immunity: Less than 0.5% of reading (SAMA PMC 33.1c test method) 20 kHz to 1,000 MHz, 10 V/meter.

Common Mode Rejection: 120 db

Reverse Polarity Protection: 42 VDC applied with either polarity.

Power and Load: Supply Voltage (No Load): 12 to 42 VDC

Supply Voltage (Under Load):

$$V_{\text{SUPPLY}} = (12) + (I_{\text{LOAD}} \text{ in K}\Omega) \times (23 \text{ mA})$$

Supply Voltage Effect: Less than ±0.005% of span/volt

Weight: 12 oz

Standard Configuration: Factory configured for direct acting 4 to 20 milliamp input. Configurations can be user-performed in analog or digital mode. Custom factory configurations are available to suit your requirements. See price list.

Options and Accessories: LD-2 Two-line "Smart Display," KB-2 Keyboard, CA-100 Communications Interface, Explosion-Proof Housings, and HHT-42 Hand-Held Terminal.

Ordering Information: Please order Model SC-2000. Specify any custom configuration, if desired. Order companion products as required.

AccutechTM
Smart Process Instrumentation

15 Bonazzoli Avenue • Riverside Industrial Park
Hudson, MA 01749 U.S.A. • TEL: (508) 568-0500
FAX: (508) 568-9085

Specifications subject to change without notice. Warranty: Adaptive Instruments Corporation warrants the 2000 series products to be free from defects in material, workmanship, and calibration under normal conditions of use and service and will repair, replace, or recalibrate free of charge any component found to be defective, if returned to AIC with transportation prepaid, within two years of original purchase. See Warranty issued with product. Printed in USA. Copyright, 1995, AIC.