



Wireless Instrumentation Radio Repeater

Long-Range Base



The Accutech Long Range Base Radio Repeater couples to an Accutech Base Radio and delivers a measurement data stream to a remote location within a plant site.

Long Range Base Radio Repeater Description

(continued)

The measurement data starts with the Wireless Field Units that are battery powered transceivers with integral sensing and signal conditioning. These establish a wireless communication link to the Base Radio; which, in turn, passes the data to the secondary repeater, located in the field, near the Base-Radio. The secondary repeater makes a wireless data retransmission to the primary repeater located where the data is needed.

The Long Range Repeater Radio is a powered radio repeater, allowing wireless data transmission at the full FCC power level limit for an unlicensed radio, providing the best possible link strength, the longest range and most reliable connection.

The repeater radio is packaged in a rugged NEMA 4X, watertight housing, with antenna cables of either 10 or 25 feet. This cable allows for remote, optimal, location of the Accutech high-gain "Yagi" and high-gain pole antennas for transmission and reception.

Specifications:

Physical Characteristics

Weather-tight and corrosion-resistant acrylic housing, rated NEMA-4X.

Communication Range

The communication range of any radio is greatly influenced by the characteristics of the installation. Maximum link margin, antenna height and obstacles in the path of the communication are the primary determinants of communication range.

Determining the effects of site-based parameters and establishing sufficient link margin emphasize the practical improvements to be realized from conducting a site survey.

Antenna placement is a major variable influencing range. Small changes in antenna placement can easily have the effect of doubling the effective working range of a wireless device. Optimal antenna placement is best determined under conditions of actual use. The flexibility afforded by the Accutech remote cable antenna allows an optimal antenna placement, as determined in a survey.

Model Selection Table

MODEL	WIRELESS INSTRUMENTATION LONG-RANGE BASE RADIO REPEATER				
WI-LR	LONG RANGE BASE RADIO REPEATER				
	CODE	COMMUNICATION DATA STREAM SELECTION			
	M	MODBUS			
	W	WIM-RS-485			
		CODE	LOCATION*		
		S	Secondary, Field-Based Remote Repeater with 6dB Yagi Antenna		
		P	Primary, Home Repeater with 6dB Pole Antenna		
			CODE	OUTPUT COMMUNICATION	
			4	RS-485 Communication Output Format	
				CODE	ANTENNA CABLE LENGTH**
			10	10 Feet Antenna Cable	
			25	25 Feet Antenna Cable	
WI-LR-	W-	S	4-	10-	TYPICAL MODEL NUMBER

*at least one primary repeater is required to complete an operating system with one or more secondary repeaters – see data sheet for data stream options

**see high gain antenna data sheet for antenna selection – each repeater radio must also have dedicated antenna

Long Range Base Radio Repeater

Data Streams

The repeater handles one data stream from the Base-Radio, i.e. either the RS485, WIM format data stream or the Modbus data stream. Each data stream is an exact copy of the base radio output data and is available for downstream processing exactly as the data stream from the Base-Radio itself.

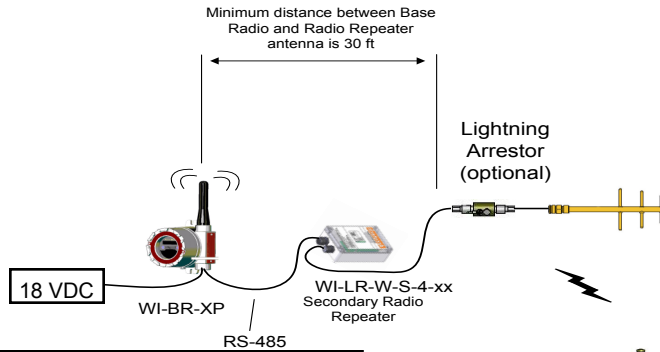

WIM Data Stream—Peer to Peer

If you are using the repeaters to send the RS-485 data in the WIM format, you can use the output from the primary repeater to the Accutech Output Modules which generate 4-20mA and contact closure signals. These modules can be daisy-chained together to generate as many analog signals as desired, and then to a PC network for configuration and network management.

When handling the formatted RS-485 base-radio data stream, one pair of repeaters is configured in a point-to-point, or single "peer-to-peer" configuration.

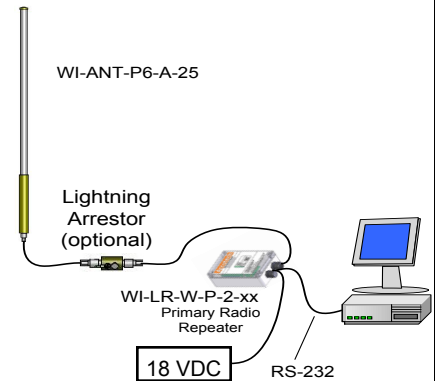

Modbus Data Stream—Point to multi-Point

If you are using the repeaters to send the Modbus data stream, you can direct this data to a PLC, DCS or other control or monitoring system. With the Modbus data, point-to-point applications are supported as well as situations where it is desired that multiple base-radios communicate to a single central point. This configuration is known as "point to multi-point", or "client-server".

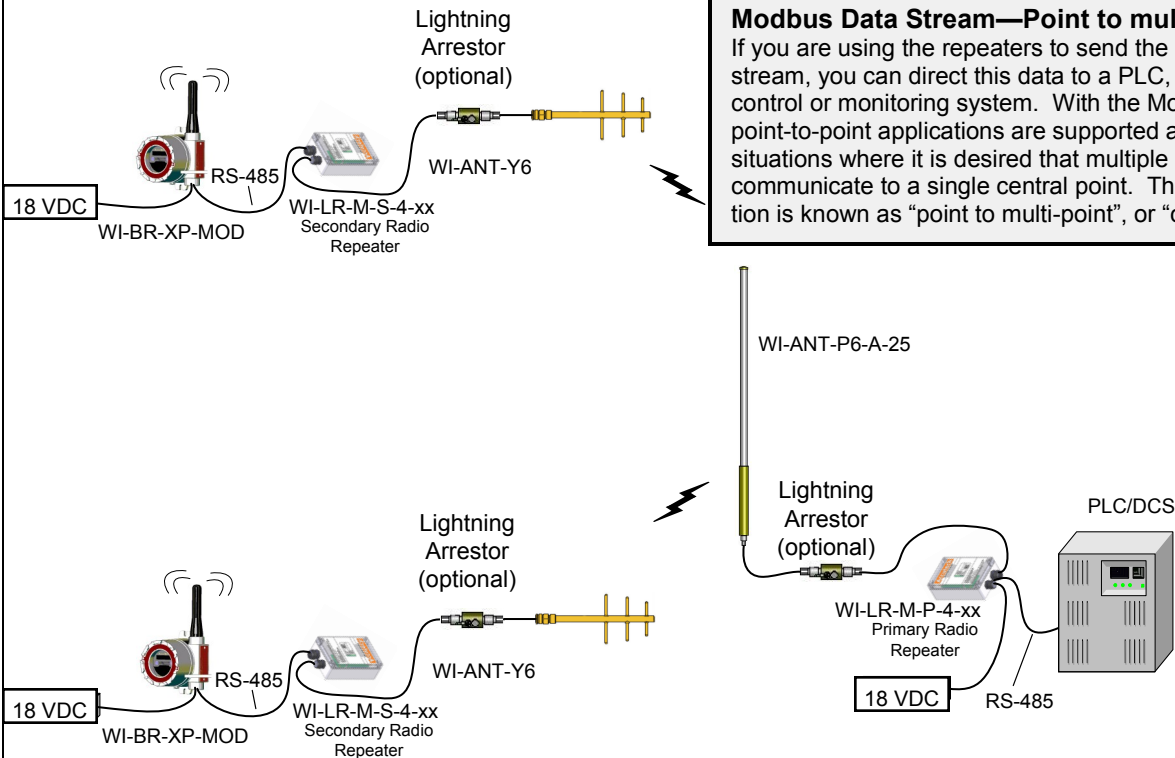

Adaptive Wireless Solutions

577 Main Street · Hudson, MA 01749 U.S.A.

TEL: 978-875-6000

FAX: 978-562-2563

Email: sales@adaptive-wireless.com

www.Adaptive-Wireless.com